

MODEL Q-1285
VOLTAGE 12
CAPACITY 192Ah @ 10Hr
MATERIAL ABS
BATTERY AGM Deep Cycle Power Battery
COLOR Brown Red
WATERING No Watering Required



12 VOLT

PHYSICAL SPECIFICATIONS

BCI	MODEL NAME	TERMINAL TYPE	DIMENSIONS ^c INCHES (mm)			WEIGHT ^d LBS. (kg)	HANDLES	INSTALLATION ORIENTATION
			LENGTH	WIDTH	HEIGHT ^f			
--	Q-1285	M8*25	19.02(483)	6.69 (170)	9.45 (240)	112 (51)	Embedded	Vertical

ELECTRICAL SPECIFICATIONS

VOLTAGE	CRANKING PERFORMANCE		CAPACITY ^a MINUTES		CAPACITY ^b AMP-HOURS (Ah)				ENERGY (kWh)	INTERNAL RESISTANCE (mΩ)	SHORT CIRCUIT CURRENT (amps)
	C.C.A. ¹ @0°F	C.A. ² @32°F	@ 25 Amps	@ 56 Amps	5-Hr	10-Hr	20-Hr	100-Hr			
12	-	-	435	168	180	192	206	228	2.75	3.5	3400

CHARGING INSTRUCTIONS

CHARGER VOLTAGE SETTINGS (AT 77°F/25°C)				
SYSTEM VOLTAGE	12V	24V	36V	48V
Maximum Charge Current (A)	15% of C _s			
Absorption Voltage (2.47 V/cell)	14.8	29.6	44.4	59.2
Float Voltage (2.30V/cell)	13.8	27.6	41.4	55.2
Do not install or charge batteries in a sealed or non-ventilated compartment. Constant under or overcharging will damage the battery and shorten its life as with any battery.				

CHARGING TEMPERATURE COMPENSATION

ADD	SUBTRACT
0.003 volt per cell for every 1°C below 25°C 0.0017 volt per cell for every 1°F below 77°F	0.003 volt per cell for every 1°C above 25°C 0.0017 volt per cell for every 1°F above 77°F

OPERATIONAL DATA

OPERATING TEMPERATURE	SELF DISCHARGE
-4°F to 113°F (-20°C to +45°C). At temperatures below 32°F (0°C) maintain a state of charge greater than 80%.	5 - 15% per month depending on storage temperature conditions .

RECYCLE RESPONSIBLY

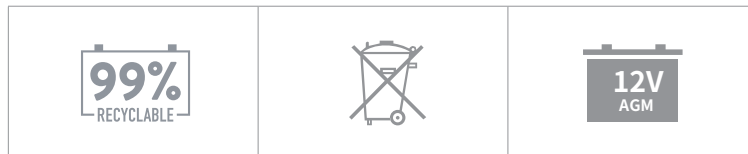

STATE OF CHARGE MEASURE OF OPEN-CIRCUIT VOLTAGE

PERCENTAGE CHARGE	CELL	12 VOLT
100	2.20	13.20
75	2.13	12.78
50	2.07	12.42
25	2.01	12.06
0	1.95	11.70

QUIMO Q-1285 PERFORMANCE(5Hr)

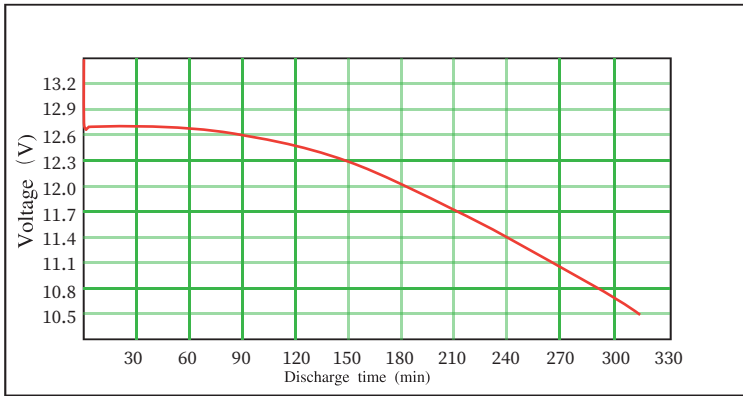

PERCENT CAPACITY VS. TEMPERATURE(5Hr)

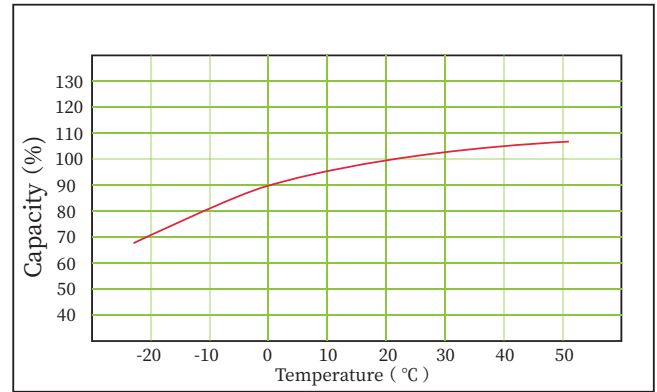

BATTERY DIMENSIONS (shown with M8)

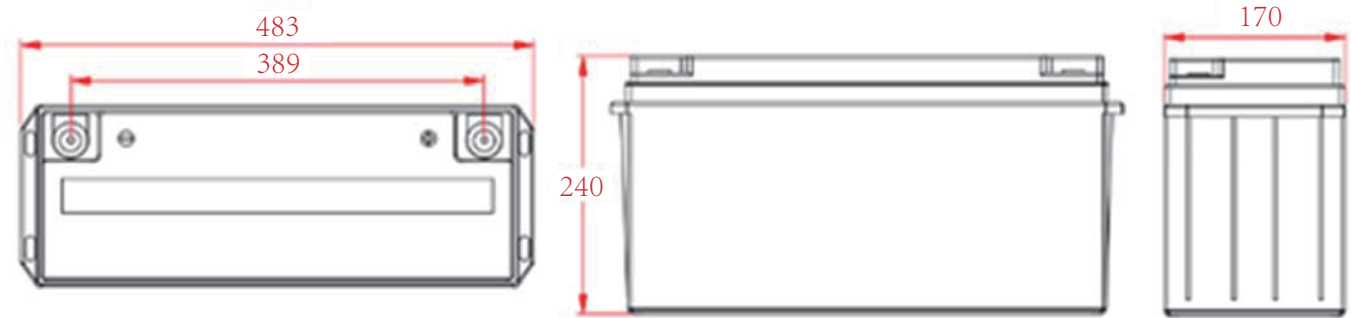

TERMINAL TYPE ^G

1	M8
	<p>Battery Height with Terminal in Inches (mm) 9.45(240)</p> <p>Screw hole size (mm) M8*25</p>

2	M8
	<p>Bolt Size (mm) M8*20</p> <p>Torque Values in-lb (Nm) 120~150 (14~17)</p>

- A. The number of minutes a battery can deliver when discharged at a constant rate at 80°F (27°C) and maintain a voltage above 1.75 V/cell. Capacities are based on peak performance.
- B. The amount of amp-hours (Ah) a battery can deliver when discharged at a constant rate at 80°F (27°C) and maintain a voltage above 1.75 V/cell. Capacities are based on peak performance.
- C. Dimensions may vary depending on type of handle or terminal. Batteries should be mounted with 0.5 inches (12.7 mm) spacing minimum.

- D. Height taken from bottom of the battery to the highest point on the battery. Heights may vary depending on type of terminal.
- E. Terminal images are representative only.
- F. Batteries in storage should be charged when they decline to 75% State of Charge (SOC).
- G. Weight may vary.



Hotline: 0513-88153000 +8618362180999
E-mail: quimobattery@163.com Website: www.quimobattery.com

Hong Kong Quimo Power Supply Co., Ltd. All rights reserved. This color page is for reference only. It is subject to change without notice. The company reserves the right to change the product design and specifications. Please check the official website of QUIMO battery (www.quimobattery.com) for the latest information.